

weldtech

WT180MP

INVERTER MULTI-PROCESS WELDER

WORKSHOP SERIES



IGBT
INVERTER
TECHNOLOGY

OPERATING INSTRUCTIONS

www.weldtech.net.nz



We Appreciate Your Business!

Congratulations on your new Weldtech product!

The Weldtech range from Euroquip uses latest technology design and engineering to produce welding products that combine market leading value and features with durability. Designed for discerning operators who seek professional results and product quality without the price tag of a full professional setup. Design emphasis is placed on simple, functional design and operation. Weldtech product is subject to stringent quality control and designed and manufactured to NZ & Australian standards.

Common use of Weldtech products include:

- Light Engineering
- Automotive
- Home/Hobby Engineering
- Farming
- Maintenance & Repairs

For industrial welding solutions, check out the Strata range from Euroquip:

www.strata.co.nz

Euroquip is a market leading provider of innovative power equipment solutions to a wide range of industries across New Zealand and Australia. Key product categories are; welding equipment, air compressors, power generators and cleaning equipment.

Euroquip's slogan is 'empowering industries', find out more about the advantage Euroquip brings at **www.euroquip.co.nz**.

Providing exceptional product support is a key component of Euroquip's market leading customer advantage focus. As part of this program, it is required for all products to be registered with Euroquip to qualify for product support. Products not registered with Euroquip are supported by a base 12 month warranty only. Spare parts and technical support will not be available for an unregistered product outside of this base warranty period. If a Euroquip dealer has not already registered your product, please register it online at www.euroquip.co.nz. To request a physical registration form, please contact Euroquip customer service on 0800 387 678.

Contents

Know Your Machine	6
Controls Explained	6
Power Supply.....	7
Operating Environment	7
Welding Settings	10
Tips & Tricks.....	10
Accessories & Spare Parts	11
Care & Maintenance	12
MIG Basic Welding Guide	12
MIG Welding Troubleshooting	16
MMA (Stick) Basic Welding Guide	18
MMA (Stick) Troubleshooting	24
TIG Basic Welding Guide	25
TIG Welding Troubleshooting.....	27
Knowledge & Resources	28
Safety.....	28
Warranty.....	33

weldtech



9 kg
Super
Lightweight

**10A
230V**
Input Power
Requirement



Earth & Arc
Leads Included

WT180MP

WORKSHOP SERIES

180A | INVERTER MULTI-PROCESS WELDER

Incorporating the latest in MIG, ARC and TIG technology, the WT180MP offers professional welding results and simple setup for all welding requirements and skill levels. The bulletproof steel chassis design ensures a lifetime of reliability and performance. Complete with 3m MB25 Binzel style MIG torch, ARC & Earth lead set and gas regulator, this unit is ready for the workshop.

- Compact design - only 9kg
- MIG ARC and TIG welding
- Latest inverter technology for the best results
- Digital voltage and amperage meters for easy set up
- MIG 144A @60%
ARC/TIG 128A @60%
- 230V single phase on 10A plug
- Lift TIG with optional TIG torch
- Exceptional results on gasless welding!



**TAKES
5KG SPOOL
OF WIRE**

**OPTIONAL
TIG TORCH
AVAILABLE**

180A

**WELDS
8MM STEEL**

**18 MONTH *
COMMERCIAL
WARRANTY**

**IGBT
INVERTER
TECHNOLOGY**

*18 Month Commercial Warranty only valid with online registration at www.weldtech.net.nz

With 10A Plug - Ideal for home or workshop power supply!

WT180MP Welding Machine

Specifications



10^A
240V

Input Power

4.5 5

Spool Size

40-
180 A

MIG Output Power

30-
150 A

ARC Output Power

144 A
60 %

MIG Duty Cycle

128 A
60 %

ARC Duty Cycle

0.6 mm
0.8 mm
0.9 mm

MIG Wire Size

16 mm
to
3.2 mm

MMA Electrode Size

16 mm

TIG Tungsten Size

Input Power	240V, 10A
Generator Capacity	8kva
Output Power	MIG: 40-180A ARC/TIG: 30-150A
MIG Duty Cycle	144A @ 60%
ARC/TIG	128 @ 60%
MIG Wire Size	0.6, 0.8, 0.9mm
Spool Size	D200 5kg
MMA Electrode Size	1.6 - 3.2mm
Drive Rollers	0.8/0.9mm
Dimensions (LxWxH)	395x165x290
Weight	9kg
Protection Class	IP21

Know Your Machine

1. MIG Torch Euro Connection
2. LCD current meter - Displays output current (amps) in real time*
3. LCD Voltage meter - Displays output voltage in real time*
4. Welding voltage adjustment knob - Adjusts welding voltage in MIG mode*
5. MIG wire feed speed adjustment knob/ Arc (Stick / TIG) current adjustment knob*
6. Overload Indicator Lamp*
7. Welding output mode switch. Sets power source in MIG, MMA or Lift TIG mode*
8. Cooling Fan Inlet (obscured)
9. MIG Torch Polarity Connection Lead
10. Negative (-) welding power output connection socket
11. Positive (+) welding power output connection socket (obscured)
12. Shielding Gas Inlet Connection
13. 240V AC mains power input lead
14. Mains power switch
15. Wire spool holder
16. Wire drive inlet guide
17. Wire feed tension adjustment
18. Wire feed tension arm
19. Wire drive roller retainer
20. Wire drive roller (obscured)

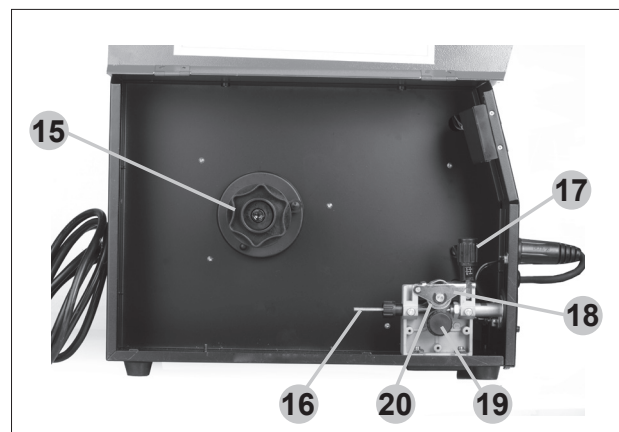
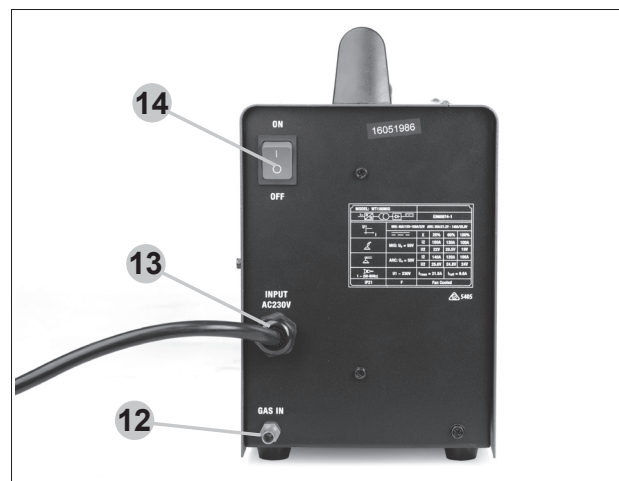
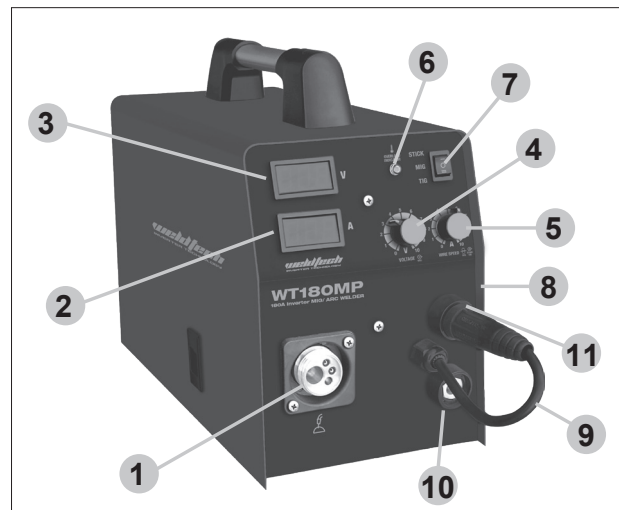

Controls Explained

LCD Current & Voltage Display Meters

These indicate the actual voltage and current readings at the output terminals of the welding machine. The current meter should read '0' except when welding is actually taking place. The voltage meter will indicate output voltage during welding and the welding open circuit voltage when the machine is powered up but not welding. In MIG mode the open circuit voltage will only appear once the torch is triggered to activate the circuit,

in MMA and Lift TIG mode, the open circuit voltage will show on the display continuously. The digital meters are very sensitive and accurate, so it is not abnormal to observe some small fluctuations on them when the machine is at rest.

WT180MP Welding Machine

MIG Voltage & MIG Wire Speed / MMA & Lift TIG Current Control Knobs

MIG Welding Mode

The MIG voltage control is essentially the power in the welding arc that sets the heat. The wire speed feed simply controls the rate at which the welding wire is fed into the weld pool.

For any voltage position setting, there will be a specific corresponding 'sweet spot' in the wire feeding speed that will give the smoothest and most stable welding arc. The correct wire feeding speed for a given voltage setting is affected by welding wire type and size, shielding gas, welding material and joint type.

It is recommended to set the welding voltage as desired and then slowly adjust the wire speed until the arc is smooth and stable. When reaching this point, if the penetration/ heat input is too much/ not enough, adjust the voltage setting and repeat the process. If the operator is not able to achieve a smooth and stable arc with the desired heat input for the weld, it is likely that a change in wire size and/or shielding gas type is required (assuming all other factors are correct).

A chart with recommended settings using this machine for common welding applications is located on the underside of the wire feeder cover door and further on in this manual.

MMA/ Lift TIG Welding Mode

The current control knob sets the target welding output current for either mode selected. The voltage knob has no effect in MMA or TIG mode.

Lift TIG Mode

Lift TIG is an arc ignition system for basic TIG welding that removes the need to 'scratch' start or strike the tungsten on the work piece to start the arc, which can have a negative effect on the weld quality due to tungsten contamination. Lift arc starting works by gently touching the tungsten on the work piece and then lifting it off. The control circuit will sense when the tungsten is removed from the work piece and send a pulse of electricity through the torch that will cause the TIG arc to initiate.

Overload Indicator Lamp

Lights when duty cycle is exceeded and thermal protection is activated. When thermal protection is activated, welding output will be disabled until machines cools sufficiently and overload indicator lamp goes out. Also may activate with inverter circuit failure issues.

Power Supply

Electrical Connection

The WT180MP is designed to operate on a 10A 240V AC power supply.

Extension Leads

If an extension cord must be used, it should be minimum cable core size 2.0mm² for length of up to 10m, or minimum 2.5mm² for length up to 20m. Using extension leads of over 20m is not recommended.

Generator Use

This machine has a wide input power variation tolerance (~170-265V), allowing it to operate off generator power. However, this machine is NOT designed for *frequent* generator use and is NOT protected against poor quality power or voltage spikes. Any damage caused by generator power supply is not covered under warranty.

If generator power must be used, generator size should be not less than 8kva. Avoid using poor, low quality generators as these have the greatest risk of power spikes etc. A suitable quality generator should have a THD (total harmonic distortion) rating of not more than 6%. Most reputable generator supplier will be able to specify the THD ratings on their product.

Operating Environment

Adequate ventilation is required to provide proper cooling for the WT180MP. Ensure that the machine is placed on a stable level surface where clean cool air can easily flow through the unit. The WT180MP has electrical components and control circuit boards which may be damaged by excessive dust and dirt, so a clean operating environment is essential.

MIG Welding Operation

1. Fitting Wire Spool

- 1.1 Open wire feeder compartment door. Fit wire spool to spool holder post. Ensure that wire exits from the bottom of the spool.

100mm/1kg Spool Set Up:

Use plastic slotted washer/spacer and threaded nut as shown here;

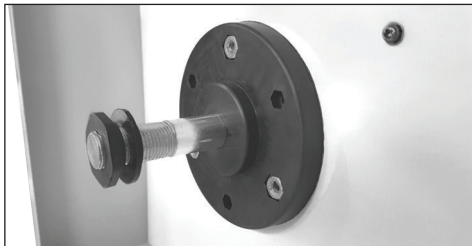

- 1.2 200mm/5kg spools only: Before replacing spool retaining nut, set spool brake tension by adjusting the smaller nut inside the spool hub. Spool should be able to rotate freely, but not continue to rotate when drive stops. Tension may need to be adjusted as spool weight decreases.



WARNING!

Excessive spool brake tension will cause wire feeding issues and affect welding performance as well as premature failure/ wear of wire feed components.

- 1.3 Feed the wire from the spool through the wire drive inlet guide (18) into the wire feeder.

2. Loading Wire Feeder

- 2.1 Release the wire feed tension arm (20) by pivoting the wire feed tension adjustment lever (19) towards you from the vertical 'locked' position.
- 2.2 Check the wire drive roller (22) groove matches the selected MIG wire type and size. The drive roller will have two different sized grooves; the size of the groove in use is stamped on the side of the drive roller. For flux cored 'soft' wire, such as that used in gasless MIG welding, the drive roller groove has a serrated profile (known as knurled). For solid core 'hard' MIG wire, the drive roller groove used has a 'v' shaped profile. If necessary, remove and change the drive roller by rotating anti clockwise and removing the drive roller retainer (21).
- 2.3 Once the correct drive roller (22) is selected and fitted and the drive roller retainer (21) is secured in place, manually feed the wire

through the wire drive inlet guide (18), through the drive roller groove and into the outlet wire guide tube. Ensuring that the wire is correctly seated in the drive roller groove, replace the wire feed tension arm (20) and lock it into place by pivoting the wire feed tension adjustment lever (19) back to the vertical position.

3. Adjusting Wire Feed Tension

This is accomplished by winding the knob on the tension adjustment lever (19). Clockwise will increase tension, anti-clockwise will decrease drive tension. Ideal tension is as little as possible, while maintaining a consistent wire feed with no drive roller slippage. Check all other causes of excess wire feeding friction causing slippage first, such as; incorrect/ worn drive roller, worn/ damaged torch consumables, blocked/ damaged torch wire guide liner, before increasing wire feed tension. There is a number scale on the tension adjustment lever (19) to indicate the adjustment position. The higher the number indicated, the higher the tension that is set.



WARNING!

Before changing the feed roller or wire spool, ensure that the mains power is switched off.



WARNING!

The use of excessive feed tension will cause rapid and premature wear of the drive roller, the support bearing and the drive motor/gearbox.

- 3.4 Check that the correct matching MIG wire, drive roller (22) and MIG torch tip are fitted.
- 3.5 Connect the machine to suitable mains power using the mains input power lead (13). Switch the mains power switch (14) to 'on' to power up the machine. Set the welding mode switch (7) to 'MIG' position.
- 3.6 You are now ready to feed the wire through the torch. With the wire feeder cover open, pull the trigger of the MIG torch to check that the wire is feeding smoothly through the feeder and into the torch.
- 3.7 Set the wire feeding speed knob (5) to maximum. With the torch tip removed from the torch and the torch laid out as straight as possible, depress MIG torch trigger until the wire feeds out through the end of the MIG torch. Replace the tip on the MIG torch and trim off any excess wire.

WT180MP Welding Machine

4. Gas MIG Welding Operation

NOTE: Gas MIG welding will require a gas cylinder.

- 4.1 Connect the earth cable quick connector to the negative welding power output socket (10). Connect the earth clamp to the work piece. Contact with the work piece must be firm, contacting with clean, bare metal, with no corrosion, paint or scale at the contact point.
- 4.2 Connect the MIG power connection lead (9) to the positive welding power output socket (11).

NOTE: If this connection is not made, there will be no electrical connection to the welding torch!

- 4.3 Connect the gas regulator to a gas cylinder (not included with machine) and connect the gas hose from the regulator to the gas inlet on the rear of the machine (12). Ensure all hose connections are tight. Open gas cylinder valve and adjust regulator, flow should be between 10-25L/min depending on application. Re-check regulator flow pressure with torch triggered as static gas flow setting may drop once gas is flowing.
- 4.4 Set the welding voltage adjustment knob (4) and wire speed control knob (5).

MIG welding with Aluminium and other soft wires.

The WT180MP is not designed or recommended for aluminium MIG welding. For MIG welding aluminium, the WT200MP is the recommended model in the Weldtech range.

5. Gasless Welding Operation

- 5.1 Connect the earth cable quick connector to the positive welding power output socket (11). Connect the earth clamp to the work piece. Contact with the work piece must be firm contact with clean, bare metal, with no corrosion, paint or scale at the contact point.
- 5.2 Connect the MIG power connection lead (9) to the negative welding power output socket (10).

NOTE: If this connection is not made, there will be no electrical connection to the welding torch!

6. ARC/ MMA Welding Operation

- 6.1 Connect the earth cable quick connector to the negative welding power output socket (10). Connect the earth clamp to the work piece. Contact with the work piece must be firm contact with clean, bare metal, with no corrosion, paint or scale at the contact point.
- 6.2 Insert an electrode into the electrode holder and connect the electrode holder and work lead to the positive welding power output socket (11).

NOTE: This polarity connection configuration is valid for most GP (General Purpose) MMA electrodes. There are variances to this. If in doubt, check the electrode specifications or consult the electrode manufacturer.

- 6.3 Connect the machine to suitable mains power using the mains input power lead (13). Switch the mains power switch (14) to 'on' to power up the machine. Set the welding mode switch (7) to 'MMA'.
- 6.4 Select the required output current using the current control knob (5). You are now ready to weld!

7. Lift TIG Operation

NOTE: Lift TIG operation requires an optional valve control TIG torch, and argon gas cylinder & regulator.

- 7.1 Connect the earth cable quick connector to the positive welding power output socket (11). Connect the earth clamp to the work piece. Contact with the work piece must be firm contact with clean, bare metal, with no corrosion, paint or scale at the contact point.
- 7.2 Insert TIG torch power connection into the negative welding power output socket (10). Connect valve TIG torch gas line to the regulator, ensuring all connections are tight.
- 7.3 Open gas cylinder valve and adjust regulator, flow should be between 5-10l/min depending on application. Re-check regulator flow pressure with torch valve open as static gas flow setting may drop once gas is flowing.
- 7.4 Connect the machine to suitable mains power using the mains input power lead (13) Switch the mains power switch (14) to 'on' to power

up the machine. Set the welding mode switch (7) to 'Lift TIG'.

- 7.5 Select the required output current using the current control knob (5). You are now ready to weld!

NOTE: The WT180MP is a DC (Direct Current) output welder only, this means that it is unable to TIG weld reactive metals such as Aluminium alloys and Brass (which require AC output). DC TIG output is suitable for steel, stainless steel and copper.

Tips & Tricks

Duty Cycle Rating

Welding duty cycle is the percentage of actual welding time that can occur in a ten minute cycle. E.g. 20% at 160 amps - this means the welder can weld at 160 amps for 2 minutes and then the unit will need to be rested for 8 minutes. All duty cycle ratings are based on an ambient air temperature of 40°C with 50% humidity, which is the international standard for such a rating. In an environment with temperatures exceeding 40°C, the duty cycle will be less than stated. In ambient temperature less than 40°C, duty cycle performance will be higher.

Welding Settings

weldtech WT180MP Welding Settings Quick Reference Chart

MIG Welding Parameter							Material Thickness			
Welding Material	Wire Type	Polarity	Wire Size	Drive Roller	Torch Liner	Shielding Gas	1.6mm	3.0mm	6.0mm	8.0mm
							Settings Key: Voltage / Wirespeed			
Mild Steel	Gasless	Torch Negative (-)	0.8mm	Knurled Groove	Blue	N/A	2/2	6/6	10/10	-
			0.9mm		Red		1/2	5/6	7/8	10/10
	Solid Steel	Torch Positive (+)	0.6mm	'V' Groove	Blue	Argon + CO ₂ Mixed (~75% Argon)	4/6	-	-	-
			0.8mm		Red		3/2	7/7	-	-
			0.9mm		Red		2/2	6/6	9/10	10/10

Use chart as guide only, as optimal settings will vary with weld joint type and operator technique. Cells left blank not recommended combination for effective welding results.

Wire Jam Troubleshooting

- If wire jam occurs when the torch becomes hot, this is often because the heat causes the wire and the tip to expand (which shrinks the hole in the tip). Using a slightly oversize tip can prevent this – eg: for 0.9mm wire, use a 1.0mm tip.
- Do NOT over-tighten the drive roll tension – this will accelerate wear of the drive system, may distort the wire & will cause further wire feed problems.
- Refer to page 15-16 for more troubleshooting tips.

WT180MP Welding Machine

Accessories & Spare Parts:

MIG Torch Spare Parts:

The MIG Torch supplied with the WT180MP is a the MT250-3E.

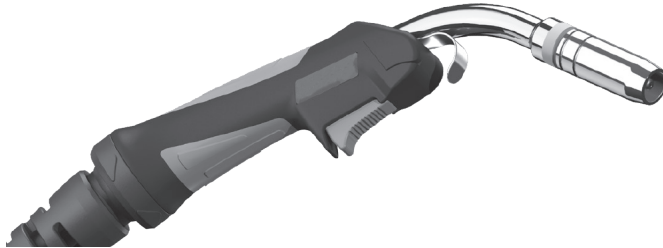

TIG Torch (Optional Extra):

The compatible TIG torch for this machine is TWP17V-12-2D TIG Torch .



Machine Spare Parts:

For Machine Parts Contact Euroquip on 0800 387 678
or email customerservice@euroquip.co.nz

Care & Maintenance

Keep your Welding Machine in Top Condition

The WT180MP does not require any special maintenance, however the user should take care of the machine as follows:

- Regularly clean the ventilation slots.
- Keep the casing clean.
- Check all cables before use.
- Check electrode holders, work lead/clamps and welding torches before use.
- Replace worn electrode holders and earth clamps, which do not provide a good connection.
- Replace worn torch consumable parts in a timely manner.
- Replace worn wire drive components in a timely manner.
- Use a soft cloth or brush to clean electrical components. Do not use liquid cleaning products, water or especially solvents.
- Do not use compressed air to clean electrical components as this can force dirt and dust further into components, causing electrical short circuits.
- Check for damaged parts.

If damaged, before further use, the welder must be carefully checked by a qualified person to determine that it will operate properly. Check for breakage of parts, mountings and other conditions that may affect its operation.

Have your welder repaired by an expert. An authorised service centre should properly repair a damaged part.

This appliance is manufactured in accordance with relevant safety standards. Only experts must carry out repairing of electrical appliances, otherwise considerable danger for the user may result. Use only genuine replacement parts. Do not use modified or non-genuine parts.

Storing the Welder

When not in use the welder should be stored in the dry and frost-free environment.



WARNING!

Before performing cleaning/maintenance, replacing cables / connections, make sure the welding machine is switched off and disconnected from the power supply.



MIG Basic Welding Guide

MIG Basic Welding Techniques

Two different welding processes are covered in this section (GMAW and FCAW), with the intention of providing the very basic concepts in MIG welding, where a welding gun is hand held, and the electrode (welding wire) is fed into a weld puddle, and the arc is shielded by a gas (GMAW) or flux cored wire (FCAW).

Gas Metal Arc Welding (GMAW)

This process, also known as MIG welding, CO₂ welding, Micro Wire Welding, short arc welding, dip transfer welding, wire welding etc., is an electric arc welding process which fuses together the parts to be welded by heating them with an arc between a solid continuous, consumable electrode and the work.

Shielding is obtained from an externally supplied welding grade shielding gas. The process is normally applied semi automatically; however the process may be operated automatically and can be machine operated. The process can be used to weld thin and fairly thick steels, and some non-ferrous metals in all positions.

GMAW Process
(Fig 1-1)

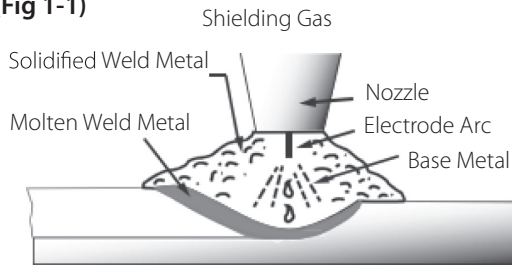

Flux Cored Arc Welding (FCAW)

This is an electric arc welding process which fuses together the parts to be welded by heating them with an arc between a continuous flux filled electrode wire and the work. Shielding is obtained through decomposition of the flux within the tubular wire. Additional shielding may or may not be obtained from an externally supplied gas or gas mixture. The process is normally applied semi automatically; however the process may be applied automatically or by machine.

It is commonly used to weld large diameter electrodes in the flat and horizontal position and small electrode diameters in all positions. The process is used to a lesser degree for welding stainless steel and for overlay work.

FCAW Process
(Fig 1-2)

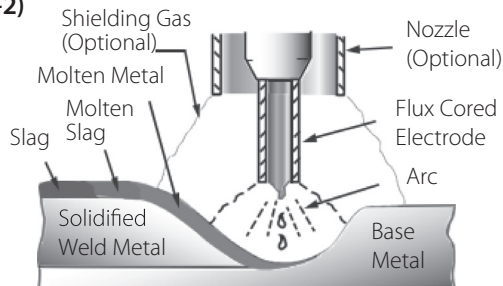

Position of MIG Torch
(Fig 1-3)

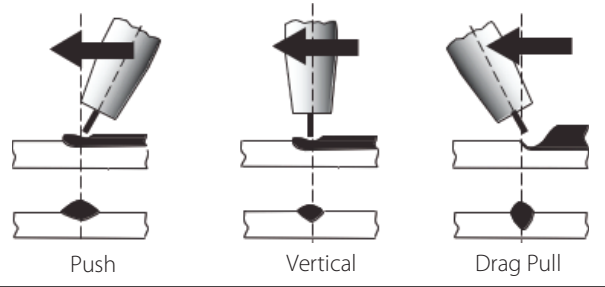

The angle of MIG torch to the weld has an effect on the width of the weld.

The welding gun should be held at an angle to the weld joint. (See Secondary Adjustment Variables below).

Hold the gun so that the welding seam is viewed at all times. Always wear the welding helmet with proper filter lenses and use the proper safety equipment.



CAUTION!!

Do not pull the welding gun back when the arc is established. This will create excessive wire extension (stick-out) and make a very poor weld.

The electrode wire is not energized until the gun trigger switch is depressed. The wire may therefore be placed on the seam or joint prior to lowering the helmet.

(Fig 1-4)

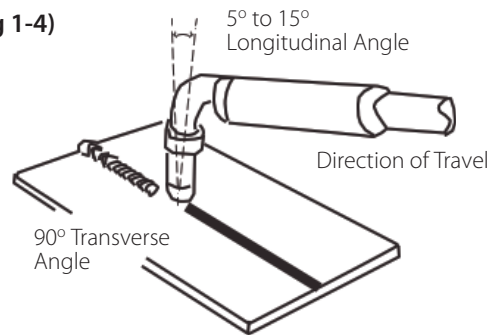

(Fig 1-5)

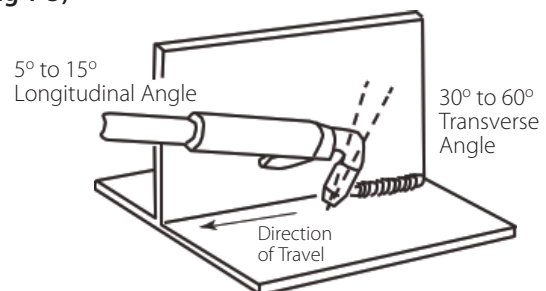

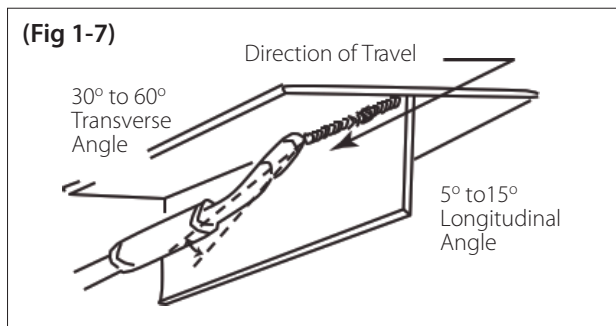
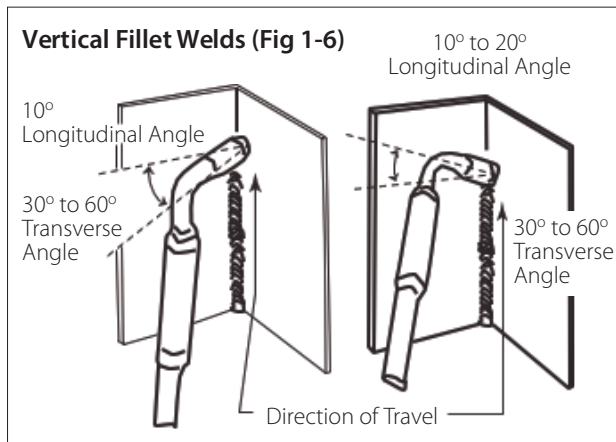

Distance from the MIG Torch Nozzle to the Work Piece

The electrode wire stick out from the MIG Torch nozzle should be between 10mm to 20mm. This distance may vary depending on the type of joint that is being welded.

Travel Speed

The speed at which the molten pool travels influences the width of the weld and penetration of the welding run.

MIG Welding (GMAW) Variables

Most of the welding done by all processes is on carbon steel. The items below describe the welding variables in short-arc welding of 24gauge (0.024", 0.6mm) to ¼" (6.4mm) mild sheet or plate. The applied techniques and end results in the GMAW process are controlled by these variables.

Preselected Variables

Preselected variables depend upon the type of material being welded, the thickness of the material, the welding position, the deposition rate and the mechanical properties.

These variables are:

- Type of electrode wire
- Size of electrode wire
- Type of gas
- Gas flow rate

Primary Adjustable Variables

These control the process after preselected variables have been found. They control the penetration, bead width, bead height, arc stability, deposition rate and weld soundness.

These variables are:

- Arc Voltage
- Welding current (wire feed speed)
- Travel speed

Secondary Adjustable Variables

These variables cause changes in primary adjustable variables which in turn cause the desired change in the bead formation. They are:

- 1. Stick-Out** (distance between the end of the contact tube (tip) and the end of the electrode wire). Maintain at about 10mm stick-out
- 2. Wire Feed Speed.** Increase in wire feed speed increases weld current. Decrease in wire feed speed decreases weld current.

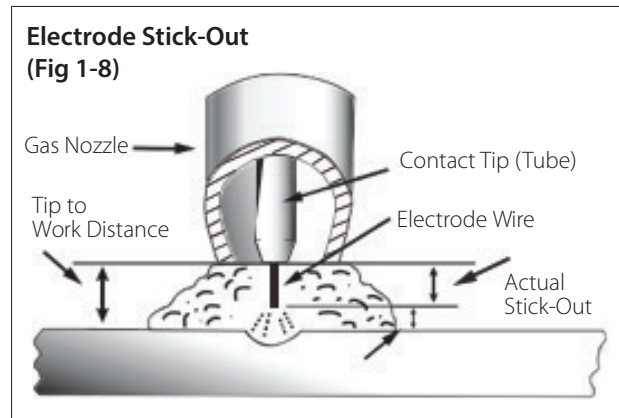

- 3. Nozzle Angle.** This refers to the position of the welding gun in relation to the joint. The transverse angle is usually one half the included angle between plates forming the joint. The longitudinal angle is the angle between the centre line of the welding gun and a line perpendicular to the axis of the weld. The longitudinal angle is generally called the Nozzle Angle and can be either trailing (pulling) or leading (pushing).

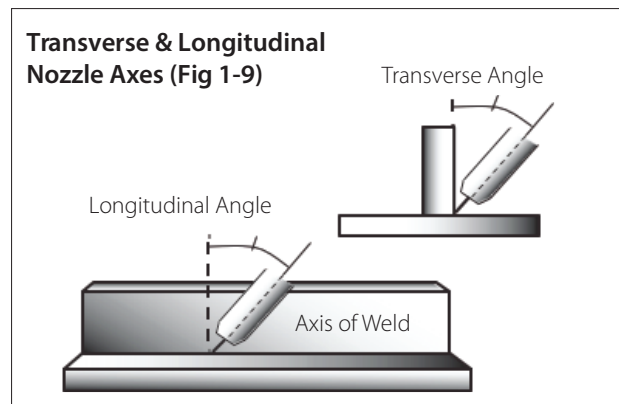

WT1 80MP Welding Machine

Whether the operator is left handed or right handed has to be considered to realize the effects of each angle in relation to the direction of travel.

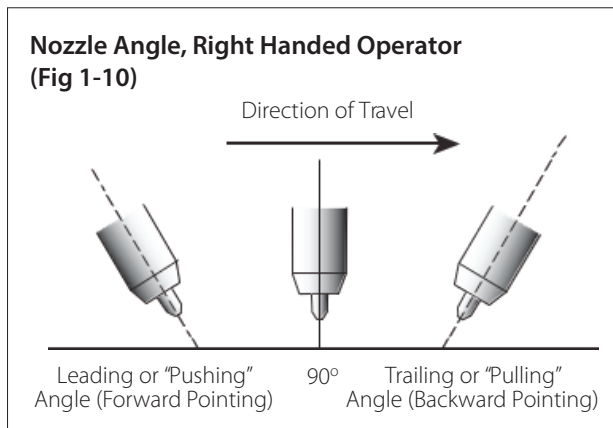

Establishing the Arc and Making Weld Beads

Before attempting to weld on a finished piece of work, it is recommended that practice welds be made on a sample metal of the same material as that of the finished piece.

The easiest welding procedure for the beginner to experiment with MIG welding is the flat position. The equipment is capable of flat, vertical and overhead positions.

For practicing MIG welding, secure some pieces of 16 or 18 gauge (1.5mm or 2.0mm) mild steel plate (150 x 150mm). Use (0.8mm) flux cored gasless wire or a solid wire with shielding gas.

Setting of the Power Source

Power source and Current (Wire Speed) setting requires some practice by the operator, as the welding plant has two control settings that have to balance. These are the Current (Wire Speed) control and the welding Voltage Control.

The welding current is determined by the Current (Wire Speed) control, the current will increase with increased Current (Wire Speed), resulting in a shorter arc. Less Current (Wire Speed) will reduce the current and lengthen the arc. Increasing the welding voltage hardly alters the current level, but lengthens the arc. By decreasing the voltage, a shorter arc is obtained with a little change in current level.

When changing to a different electrode wire diameter, different control settings are required. A thinner electrode wire needs more Current



(Wire Speed) to achieve the same current level. A satisfactory weld cannot be obtained if the Current (Wire Speed) and Voltage settings are not adjusted to suit the electrode wire diameter and the dimensions of the work piece.

If the Current (Wire Speed) is too high for the welding voltage, "sticking" will occur as the wire dips into the molten pool and does not melt. Welding in these conditions normally produces a poor weld due to lack of fusion. If, however, the welding voltage is too high, large drops will form on the end of the wire, causing spatter. The correct setting of voltage and Current (Wire Speed) can be seen in the shape of the weld deposit and heard by a smooth regular arc sound.

Electrode Wire Size Selection

The choice of Electrode wire size and shielding gas used depends on the following:

- Thickness of the metal to be welded
- Type of joint
- Capacity of the wire feed unit and power source
- The amount of penetration required
- The deposition rate required
- The bead profile desired
- The position of welding
- Cost of the wire

MIG Welding Troubleshooting

The general approach to fix Gas Metal Arc Welding (GMAW) problems is to start at the wire spool then work through to the MIG torch. There are two main areas where problems occur with GMAW, Porosity and Inconsistent wire feed.

When there is a gas problem the result is usually porosity within the weld metal. Porosity always stems from some contaminant within the molten weld pool which is in the process of escaping during solidification of the molten metal.

Contaminants range from no gas around the welding arc to dirt on the workpiece surface. Porosity can be reduced by checking the following points.

Troubleshooting - Porosity	
Fault	Cause
Shielding gas cylinder contents and flow meter.	Ensure that the shielding gas cylinder is not empty and the flow meter is correctly adjusted to 15 litres per minute.
Gas leaks.	Check for gas leaks between the regulator/cylinder connection and in the gas hose to the Power Source.
Internal gas hose in the Power Source.	Ensure the hose from the solenoid valve to the torch adaptor has not fractured and that it is connected to the torch adaptor.
Welding in a windy environment.	Shield the weld area from the wind or increase the gas flow.
Welding dirty, oily, painted, oxidised or greasy plate.	Clean contaminates off the work piece.
Distance between the MIG torch nozzle and the work piece.	Keep the distance between the MIG torch nozzle and the work piece to a minimum.
Maintain the MIG torch in good working order.	Ensure that the gas holes are not blocked and gas is exiting out of the torch nozzle.
	Do not restrict gas flow by allowing spatter to build up inside the torch nozzle.
	Check that the MIG torch O-rings are not damaged.



WARNING!

Disengage the feed roll when testing for gas flow by ear.

Wire feeding problems can be reduced by checking the following points.

Troubleshooting - Wire Feed	
Fault	Cause
Feed roller driven by motor in the cabinet slipping.	Wire spool brake is too tight.
Wire spool unwound and tangled.	Wire spool brake is too loose.
Worn or incorrect feed roller size	Use a feed roller matched to the size you are welding.
	Replace feed roller if worn.
Wire rubbed against the misaligned guides affecting the wire feed.	Misalignment of inlet/outlet guides.
Liner blocked with swarf.	Increased amounts of swarf are produced by the wire passing through the feed roller when excessive pressure is applied to the pressure roller adjuster.
	Swarf can also be produced by the wire passing through an incorrect feed roller groove shape or size.
	Swarf is fed into the conduit liner where it accumulates thus reducing wire feed.
Incorrect or worn contact tip.	The contact tip transfers the weld current to the electrode wire. If the hole in the contact tip is too large then arcing may occur inside the contact tip resulting in the wire jamming in the contact tip.
	When using soft wire such as aluminium it may become jammed in the contact tip due to expansion of the wire when heated. A contact tip designed for soft wires should be used.
Poor work lead contact to work piece.	If the work lead has a poor electrical contact to the work piece then the connection point will heat up and result in a reduction of power at the arc.
Bent liner.	This will cause friction between the wire and the liner thus reducing wire feed.

WT1 80MP Welding Machine



Other weld problems can be reduced by checking the following points.

Troubleshooting - MIG Weld Quality		
Fault	Cause	Remedy
Undercut.	Welding arc voltage too high.	Decrease voltage or increase the wire feed speed.
	Incorrect torch angle.	Adjust angle.
	Excessive heat input.	Increase the torch travel speed and/or decrease welding current by decreasing the voltage or decreasing the wire feed speed.
Lack of penetration.	Welding current too low.	Increase welding current by increasing wire feed speed and increasing voltage.
	Joint preparation too narrow or gap too tight.	Increase joint angle or gap.
	Shielding gas incorrect.	Change to a gas which gives higher penetration.
Lack of fusion.	Voltage too low.	Increase voltage.
Excessive spatter.	Voltage too high.	Decrease voltage or increase the Current (Wire Speed) control.
	Voltage too low.	Increase the voltage or decrease Current (Wire Speed).
Irregular weld shape.	Incorrect voltage and current settings. Convex, voltage too low. Concave, voltage too high.	Adjust voltage and current by adjusting the voltage control and the Current (Wire Speed) control.
	Wire is wandering.	Replace contact tip.
	Incorrect shielding gas.	Check shielding gas.
	Insufficient or excessive heat input.	Adjust the Current (Wire Speed) control or the voltage control.
Weld cracking.	Weld bead is too small.	Decrease travel speed.
	Weld penetration narrow and deep.	Reduce current and voltage and increase MIG torch travel speed or select a lower penetration shielding gas.
	Excessive weld stresses.	Increase weld metal strength or revise design.
	Excessive voltage.	Decrease voltage.
	Cooling rate too fast.	Slow the cooling rate by preheating part to be welded or cool slowly.
Cold weld puddle.	Loose welding cable connection.	Check all welding cable connections.
	Low power supply voltage.	Contact supply authority.
Arc does not have a crisp sound that short arc exhibits when the wire feed speed and voltage are adjusted correctly.	The MIG torch has been connected to the wrong voltage polarity on the front panel.	Connect the MIG torch to the positive (+) welding terminal for solid wires and gas shielded flux cored wires. Refer to the electrode wire manufacturer for the correct polarity.

MMA (Stick) Basic Welding Guide

Size of Electrodes

The electrode size is determined by the thickness of metals being joined and can also be governed by the type of welding machine available. Small welding machines will only provide current (amperage) to run smaller sized electrodes.

For thin sections, it is necessary to use smaller electrodes otherwise the arc may burn holes through the job. A little practice will soon establish the most suitable electrode for a given application.

Storage of Electrodes

Always store electrodes in a dry place and in their original containers.

Electrode Polarity

Electrodes are generally connected to the electrode holder with the electrode holder connected positive polarity.

The work lead is connected to the negative polarity and is connected to the work piece. If in doubt consult the electrode data sheet.

Effects of MMA(Stick) Welding on Various Materials

High Tensile and Alloy Steels

The two most prominent effects of welding these steels are the formation of a hardened zone in the weld area, and, if suitable precautions are not taken, the occurrence in this zone of under-bead cracks. Hardened zone and underbead cracks in the weld area may be reduced by using the correct electrodes, preheating, using higher current settings, using larger electrodes sizes, short runs for larger electrode deposits or tempering in a furnace.

Manganese Steels

The effect on manganese steel of slow cooling from high temperatures causes embrittlement. For this reason it is absolutely essential to keep manganese steel cool during welding by quenching after each weld or skip welding to distribute the heat.

Cast Iron

Most types of cast iron, except white iron, are weldable. White iron, because of its extreme

Flat Position, Down Hand Butt Weld (Fig 1-11)

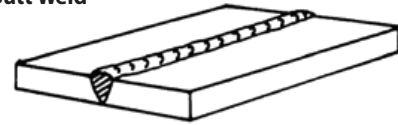

Flat Position, Gravity Fillet Weld (Fig 1-12)

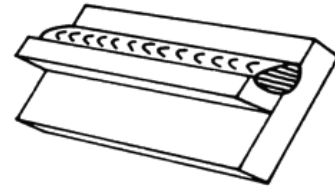

Horizontal Position, Butt Weld (Fig 1-13)

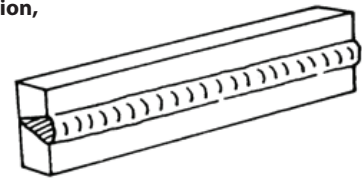

Horizontal-Vertical (HV) Position (Fig 1-14)

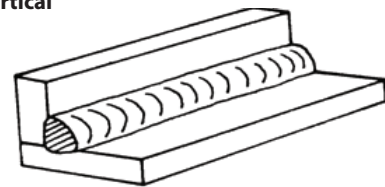

Vertical Position, Butt Weld (Fig 1-15)

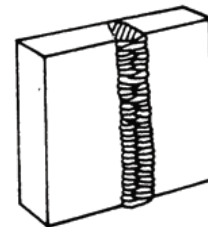

Vertical Position, Fillet Weld (Fig 1-16)

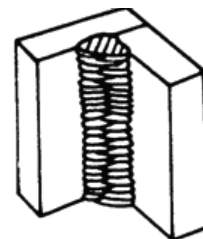

Overhead Position, Butt Weld (Fig 1-17)

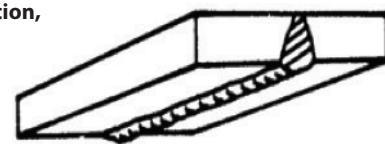

Overhead Position, Fillet Weld (Fig 1-18)

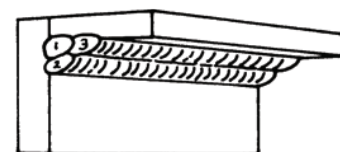

WT1 80MP Welding Machine

brittleness, generally cracks when attempts are made to weld it. Trouble may also be experienced when welding white-heart malleable, due to the porosity caused by gas held in this type of iron.

Copper and Alloys

The most important factor is the high rate of heat conductivity of copper, making pre-heating of heavy sections necessary to give proper fusion of weld and base metal.

Types of Electrodes

Arc Welding electrodes are classified into a number of groups depending on their applications. There are a great number of electrodes used for specialised industrial purposes which are not of particular interest for everyday general work. These include some low hydrogen types for high tensile steel, cellulose types for welding large diameter pipes, etc. The range of electrodes dealt with in this publication will cover the vast majority of applications likely to be encountered; are all easy to use.

Electrodes for joining different metals:

MILD STEEL :

E6013 - This all-position electrode is used for welding clean, new sheet metal. Its soft arc has minimal spatter, moderate penetration and an easy-to-clean slag.

E7018 - A low-hydrogen, all-position electrode used when quality is an issue or for hard-to-weld metals. It has the capability of producing more uniform weld metal, which has better impact properties at low temperatures.

312 Weldall - Allows welding of dissimilar steels for a high strength, crack resistant weld

HF600 Hard Facing - Designed to deposit long lasting, wear resistant overlays on all ferrous metals where high impact and abrasion resistance is required.

CAST IRON:

NiFe - Suitable for joining cast irons

STAINLESS STEEL:

316L - Low carbon & rutile coated for premium welding quality of 300 series stainless steels.

Joint Preparations

In many cases, it will be possible to weld steel sections without any special preparation. For heavier sections and for repair work on castings, etc., it will be necessary to cut or grind an angle

between the pieces being joined to ensure proper penetration of the weld metal and to produce sound joints. In general, surfaces being welded should be clean and free of rust, scale, dirt, grease, etc. Slag should be removed from oxy-cut surfaces. Typical joint designs are shown in Figure 1-19.

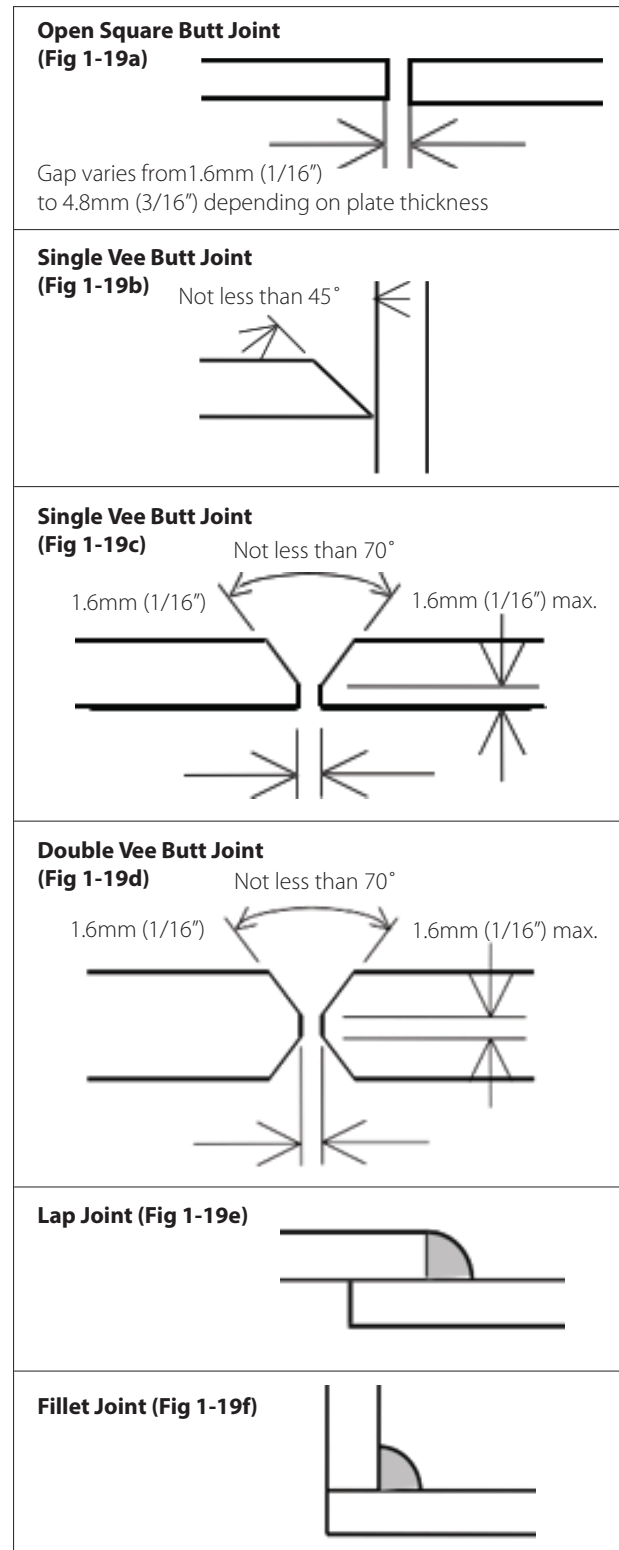

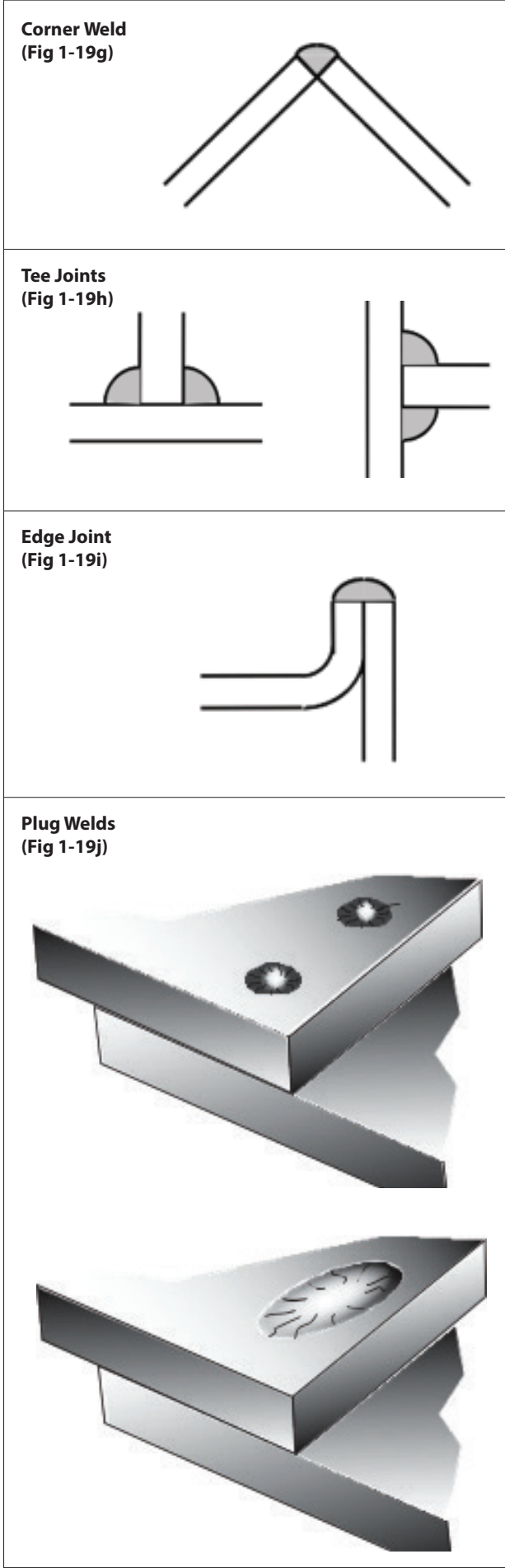

MMA Welding Techniques - A Word for Beginners

For those who have not yet done any welding, the simplest way to commence is to run beads on a piece of scrap plate. Use mild steel plate about 6.0mm thick and a 3.2mm electrode.

Clean any paint, loose scale or grease off the plate and set it firmly on the work bench so that welding can be carried out in the down hand position. Make sure that the Work Lead/Clamp is making good electrical contact with the work, either directly or through the work table. For light gauge material, always clamp the work lead directly to the job, otherwise a poor circuit will probably result.

The Welder

Place yourself in a comfortable position before beginning to weld. Get a seat of suitable height and do as much work as possible sitting down. Don't hold your body tense. A taut attitude of mind and a tensed body will soon make you feel tired. Relax and you will find that the job becomes much easier. You can add much to your peace of mind by wearing a leather apron and gauntlets. You won't be worrying then about being burnt or sparks setting alight to your clothes.

Place the work so that the direction of welding is across, rather than to or from, your body. The electrode holder lead should be clear of any obstruction so that you can move your arm freely along as the electrode burns down. If the lead is slung over your shoulder, it allows greater freedom of movement and takes a lot of weight off your hand. Be sure the insulation on your cable and electrode holder is not faulty; otherwise you are risking an electric shock.

Striking the Arc

Practice this on a piece of scrap plate before going on to more exacting work. You may at first experience difficulty due to the tip of the electrode "sticking" to the work piece. This is caused by making too heavy a contact with the work and failing to withdraw the electrode quickly enough. A low amperage will accentuate it. This freezing-on of the tip may be overcome by scratching the electrode along the plate surface in the same way as a match is struck. As soon as the arc is established, maintain a 1.6mm to 3.2mm gap between the burning electrode end and the parent metal. Draw

the electrode slowly along as it melts down.

Another difficulty you may meet is the tendency, after the arc is struck, to withdraw the electrode so far that the arc is broken again. A little practice will soon remedy both of these faults.

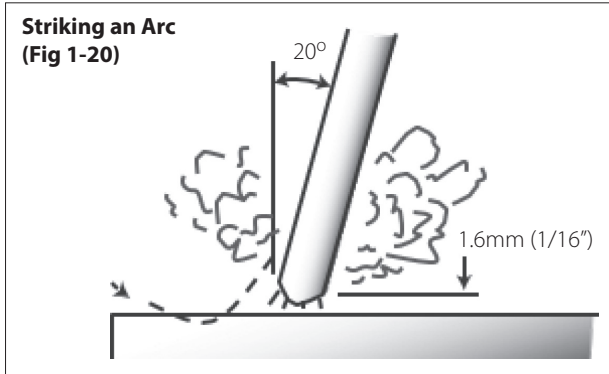

Arc Length

The securing of an arc length necessary to produce a neat weld soon becomes almost automatic. You will find that a long arc produces more heat.

A very long arc produces a crackling or spluttering noise and the weld metal comes across in large, irregular blobs. The weld bead is flattened and spatter increases. A short arc is essential if a high quality weld is to be obtained although if it is too short there is the danger of it being blanketed by slag and the electrode tip being solidified in. If this should happen, give the electrode a quick twist back over the weld to detach it. Contact or "touch-weld" electrodes such as Stick electrodes do not stick in this way, and make welding much easier.

Rate of Travel

After the arc is struck, your next concern is to maintain it, and this requires moving the electrode tip towards the molten pool at the same rate as it is melting away. At the same time, the electrode has to move along the plate to form a bead.

The electrode is directed at the weld pool at about 20° from the vertical. The rate of travel has to be adjusted so that a well-formed bead is produced.

If the travel is too fast, the bead will be narrow and strung out and may even be broken up into individual globules. If the travel is too slow, the weld metal piles up and the bead will be too large.

Making Welded Joints

Having attained some skill in the handling of an electrode, you will be ready to go on to make up welded joints.

A. Butt Welds

Set up two plates with their edges parallel, as shown in Figure 1-21, allowing 1.6mm to 2.4mm gap between them and tack weld at both ends. This is to prevent contraction stresses from the cooling weld metal pulling the plates out of alignment.

Plates thicker than 6.0mm should have their mating edges beveled to form a 70° to 90° included angle. This allows full penetration of the weld metal to the root. Using a 3.2mm Stick electrode at 100 amps, deposit a run of weld metal on the bottom of the joint.

Do not weave the electrode, but maintain a steady rate of travel along the joint sufficient to produce a well-formed bead. At first you may notice a tendency for undercut to form, but keeping the arc length short, the angle of the electrode at about 20° from vertical, and the rate of travel not too fast, will help eliminate this.

The electrode needs to be moved along fast enough to prevent the slag pool from getting ahead of the arc. To complete the joint in thin plate, turn the job over, clean the slag out of the back and deposit a similar weld.

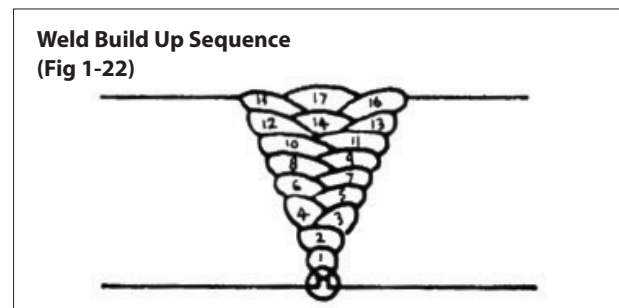
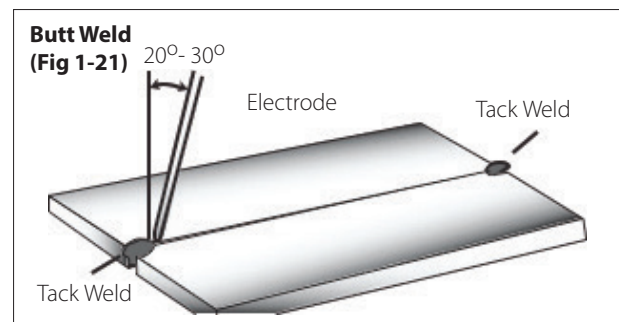

Heavy plate will require several runs to complete the joint. After completing the first run, chip the slag out and clean the weld with a wire brush. It is important to do this to prevent slag being trapped by the second run. Subsequent runs are then deposited using either a weave technique or single beads laid down in the sequence shown in Figure 1-22. The width of weave should not be more than three times the core wire diameter of the electrode.

When the joint is completely filled, the back is either machined, ground or gouged out to remove slag which may be trapped in the root, and to prepare a suitable joint for depositing the backing run. If a backing bar is used, it is not usually necessary to remove this, since it serves a similar purpose to the backing run in securing proper fusion at the root of the weld.

B. Fillet Welds

These are welds of approximately triangular cross-section made by depositing metal in the corner of two faces meeting at right angles. Refer to Figure 1-14, 1-23 and 1-24.

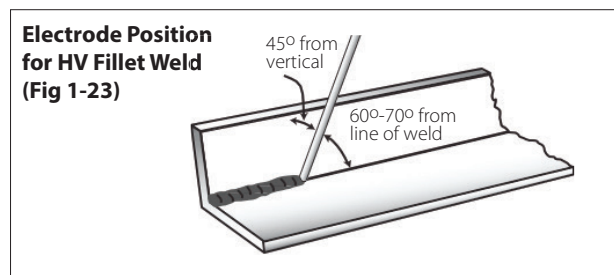

A piece of angle iron is a suitable specimen with which to begin, or two lengths of strip steel may be tacked together at right angles. Using a 3.2mm Stick electrode at 100 amps, position angle iron with one leg horizontal and the other vertical. This is known as a horizontal-vertical (HV) fillet.

Strike the arc and immediately bring the electrode to a position perpendicular to the line of the fillet and about 45° from the vertical. Some electrodes require being sloped about 20° away from the perpendicular position to prevent slag from running ahead of the weld. Refer to Figure 1-23.

Do not attempt to build up much larger than 6.4mm width with a 3.2mm electrode, otherwise the weld metal tends to sag towards the base, and undercut forms on the vertical leg. Multi-runs can be made as shown in Figure 1-24. Weaving in HV fillet welds is undesirable.

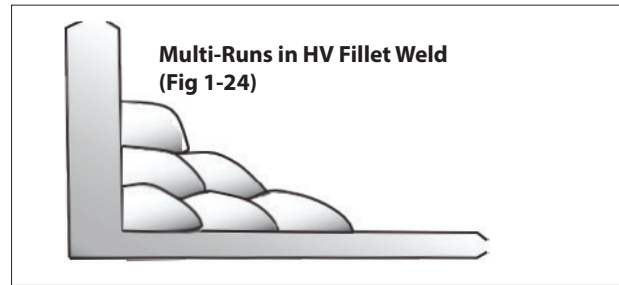

C. Vertical Welds

1. Vertical Up

Tack weld a three feet length of angle iron to your work bench in an upright position. Use a 3.2mm Stick electrode and set the current at 100 amps. Make yourself comfortable on a seat in front of the job and strike the arc in the corner of the fillet. The electrode needs to be about 10° from the horizontal to enable a good bead to be deposited. Refer Fig. 1-25.

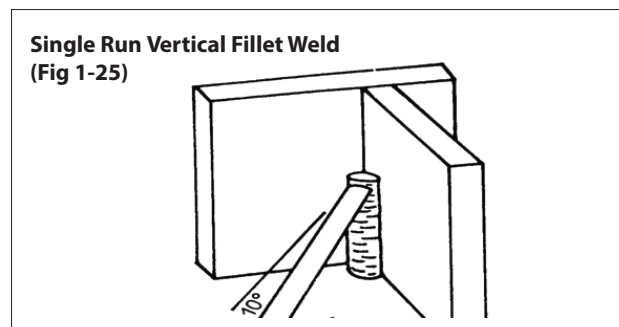

Use a short arc, and do not attempt to weave on the first run. When the first run has been completed deslag the weld deposit and begin the second run at the bottom. This time a slight weaving motion is necessary to cover the first run and obtain good fusion at the edges.

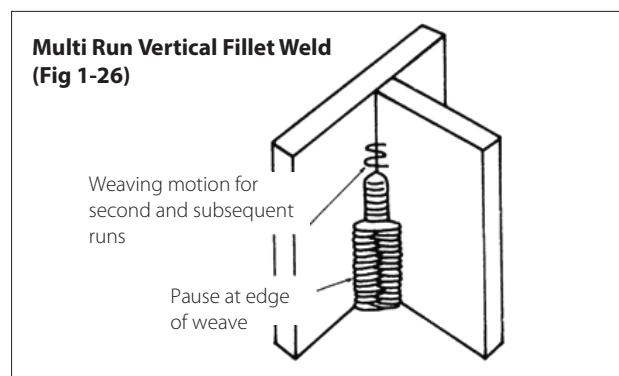

At the completion of each side motion, pause for a moment to allow weld metal to build up at the edges, otherwise undercut will form and too much metal will accumulate in the centre of the weld. Figure 1-26 illustrates multi-run technique and Figure 1-27 shows the effects of pausing at the edge of weave and of weaving too rapidly.

**Examples of Vertical Fillet Welds
(Fig 1-27)**

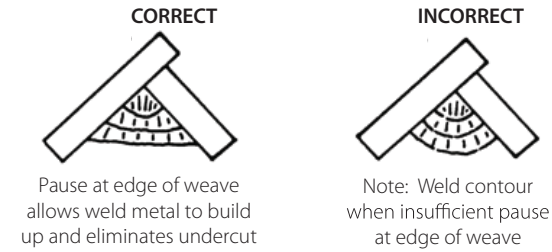

2. Vertical Down

Use a 3.2mm electrode at 100 amps. The tip of the electrode is held in light contact with the work and the speed of downward travel is regulated so that the tip of the electrode just keeps ahead of the slag. The electrode should point upwards at an angle of about 45°.

3. Overhead Welds

Apart from the rather awkward position necessary, overhead welding is not much more difficult than down hand welding. Set up a specimen for overhead welding by first tacking a length of angle

iron at right angles to another piece of waste pipe. Then tack this to the work bench or hold in a vice so that the specimen is positioned in the overhead position as shown in the sketch.

The electrode is held at 45° to the horizontal and tilted 10° in the line of travel (Figure 1-28). The tip of the electrode may be touched lightly on the metal, which helps to give a steady run. A weave technique is not advisable for overhead fillet welds.

Use a 3.2mm E6013 Stick electrode at 100 amps, and deposit the first run by simply drawing the electrode along at a steady rate. You will notice that the weld deposit is rather convex, due to the effect of gravity before the metal freezes.

**Overhead Fillet Weld
(Fig 1-28)**

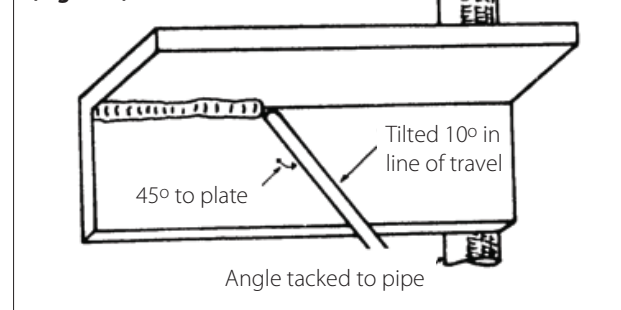

MMA (Stick) Troubleshooting

Fault	Cause	Remedy
A gap is left by failure of the weld metal to fill the root of the weld.	Welding current too low.	Increase welding current.
	Electrode too large for joint.	Use smaller diameter electrode.
	Insufficient gap.	Allow wider gap.
Non-metallic particles are trapped in the weld metal.	Non-metallic particles may be trapped in undercut from previous run.	If a bad undercut is present clean slag bout and cover with a run from a smaller gauge electrode.
	Joint preparation too restricted.	Allow for adequate penetration and room for cleaning out the slag.
	Irregular deposits allow slag to be trapped.	If very bad, chip or grind out irregularities.
	Lack of penetration with slag trapped beneath weld bead.	Use smaller electrode with sufficient current to give adequate penetration. Use suitable tools to remove all slag from comers.
	Rust or mill scale is preventing full fusion.	Clean joint before welding.
Wrong electrode for position in which welding is done.	Use electrodes designed for position in which welding is done, otherwise proper control of slag is difficult.	
<p>Figure 1: Example of insufficient gap or incorrect sequence</p> <div style="display: flex; align-items: center;"> <div style="margin-right: 20px;"> <p>Incorrect Sequence</p> <p>Insufficient Gap</p> </div> </div>		
A groove has been formed in the base metal adjacent to the toe of a weld and has not been filled by the weld metal (undercut).	Welding current is too high.	Reduce welding current.
	Welding arc is too long.	Reduce the length of the welding arc.
	Angle of the electrode is incorrect.	Electrode should not be inclined less than 45° to the vertical face.
	Joint preparation does not allow correct electrode angle.	Allow more room in joint for manipulation of the electrode.
	Electrode too large for joint.	Use smaller gauge electrode.
	Insufficient deposit time at edge of weave.	Pause for a moment at edge of weave to allow weld metal build-up.
	Power source is set for MIG (GMAW) welding.	Set power source to STICK (MMA) mode.
Portions of the weld run do not fuse to the surface of the metal or edge of the joint.	Small electrodes used on heavy cold plate.	Use larger electrodes and preheat the plate.
	Welding current is too low.	Increase welding current.
	Wrong electrode angle.	Adjust angle so the welding arc is directed more into the base metal.
	Travel speed of electrode is too high.	Reduce travel speed of electrode.
	Scale or dirt on joint surface.	Clean surface before welding.
<p>Figure 2: Example of Lack of Fusion</p> <div style="display: flex; align-items: center;"> <div style="margin-right: 20px;"> <p>Lack of fusion caused by dirt; electrode angle incorrect; rate of travel too high</p> <p>Lack of side fusion, scale dirt; small electrode; amperage too low</p> </div> </div>		
Gas pockets or voids in weld metal (porosity)	High levels of sulphur in steel.	Use an electrode that is designed for high sulphur steels.
	Electrodes are damp.	Dry electrodes before use.
	Welding current is too high.	Reduce welding current.
	Surface impurities such as oil, grease, paint, etc.	Clean joint before welding.
	Welding in a windy environment.	Shield the weld area from the wind.
	Electrode damaged i.e. flux coating incomplete.	Discard damaged electrodes and only use electrodes with a complete flux coating.
Crack occurring in weld metal soon after solidification commences	Rigidity of joint.	Redesign to relieve weld joint of severe stresses or use crack resistance electrodes.
	Insufficient throat thickness.	Travel slightly slower to allow greater build up in throat.
	Weld current is too high.	Decrease welding current.
<p>Figure 3: Example of Slag Inclusion</p> <div style="display: flex; justify-content: space-around; align-items: center;"> <div style="text-align: center;"> <p>Not cleaned, or incorrect electrode</p> </div> <div style="text-align: center;"> </div> </div>		

TIG Basic Welding Guide

TIG Welding is a fusion procedure that uses an electric ARC created between an infusible tungsten electrode and base material to be welded. For TIG welding an inert gas must be used (Argon) which protects the welding bead. If filling material is used, it is made up of rods suitable to the material to be welded (steel, stainless steel, copper etc).

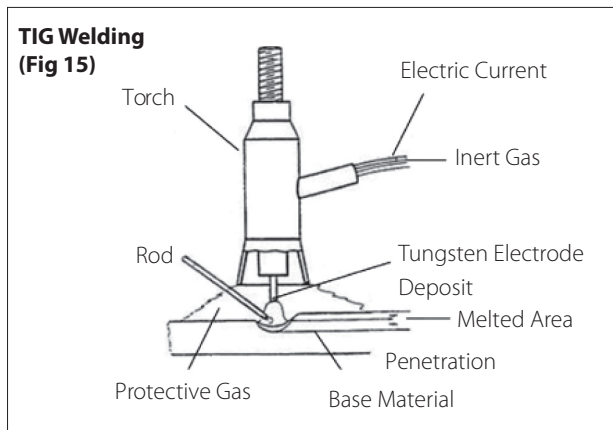

In TIG mode, welding is possible in all positions: flat, angle, on the edge, vertical and overhead. Furthermore, with respect to other types of welding, the welding joint has greater mechanical resistance, greater corrosion resistance and limited heating in the welded area which limits distortion. Welding can be done even without weld material, guaranteeing a smooth, shiny weld with no impurities or slag.

TIG Electrode Selection and Preparation

Electrode Polarity

Connect the TIG torch to the negative (-) torch terminal and the work lead to the positive (+) work terminal for direct current straight polarity. Direct current straight polarity is the most widely used polarity for DC TIG welding. It allows limited wear of the electrode since 70% of the heat is concentrated at the work piece.

Tungsten Electrode Types			
Electrode Type (Ground Finish)	Application	Features	Colour Code
Thoriated 2%	DC welding of mild steel, stainless steel and copper.	Excellent arc starting; long life; high current capacity.	Red
Ceriated 2%	DC welding of mild steel, stainless steel and copper.	Longer life; more stable arc; easier starting; wider current range; narrower, more concentrated arc.	Grey

Tungsten Electrode Current Ranges	
Electrode Diameter	DC Current (Amps)
1.0mm (0.040")	30 - 60
1.6mm (1/16")	60 - 115
2.4mm (3/32")	100 - 165
3.2mm (1/8")	135 - 200
4.0mm (5/32")	190 - 280
4.8mm (3/16")	250 - 340

Guide For Selecting Filler Wire Diameter	
Filler Electrode Diameter	DC Current (Amps)
1.6mm (1/16")	20 - 90
2.4mm (3/32")	65 - 115
3.2mm (1/8")	100 - 165
4.8mm (3/16")	200 - 350

Preparing Tungsten for DC Electrode Negative (DCEN) Welding

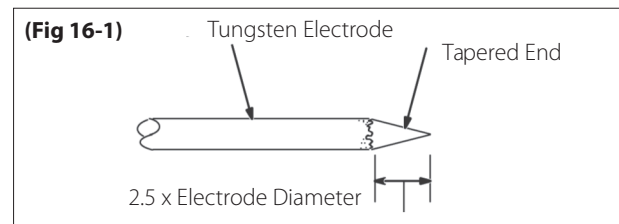

2.5 x Electrode Diameter

Grind end of tungsten on fine grit, hard abrasive wheel before welding. Do not use wheel for other jobs or tungsten can become contaminated causing lower weld quality.

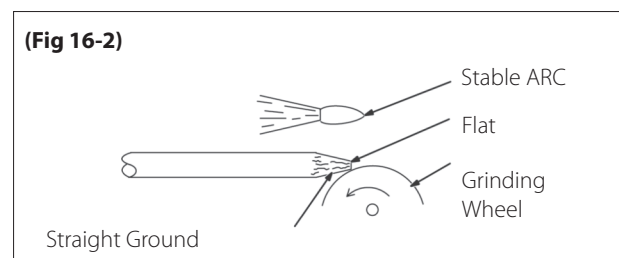

Ideal Tungsten Preparation - Stable ARC
Diameter of the flat determines amperage capacity.

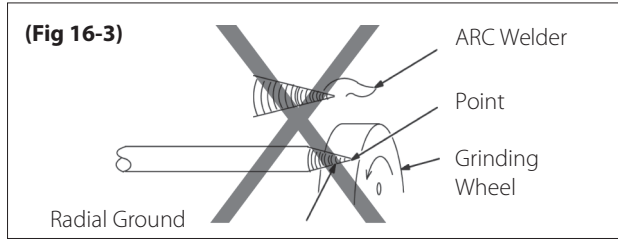

Wrong Tungsten Preparation - Wandering ARC
Diameter of the flat determines amperage capacity.

Shielding Gas Selection	
Aloy	Shielding Gas
Carbon Steel	Welding Argon
Stainless Steel	Welding Argon
Nickel Alloy	Welding Argon
Copper	Welding Argon
Titanium	Welding Argon

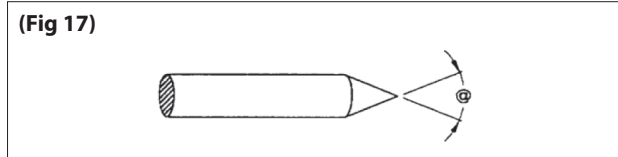

Pointing the Electrode
The electrode should be pointed according to the welding current.

Electrode Angles	
Angle @	Range of Current (Amps)
30°	0 - 30
60-90°	30 - 120
90-120°	120 - 250
120°	> 250

TIG Welding Parameters for Steel						
Base Metal Thickness	DC Current for Mild Steel	DC Current for Stainless Steel	Tungsten Electrode Diameter	Filler Rod Diameter (if required)	Argon Gas Flow Rate L/min	Joint Type
1.0mm (0.040")	35 - 45	20 - 30	1.0mm (0.040")	1.6mm (1/16")	5 - 7	Butt / Corner
	40 - 50	25 - 35				Lap / Fillet
1.2mm (0.045")	45 - 55	30 - 45	1.0mm (0.040")	1.6mm (1/16")	5 - 7	Butt / Corner
	50 - 60	35 - 50				Lap / Fillet
1.6mm (1/16")	60 - 70	40 - 60	1.6mm (1/16")	1.6mm (1/16")	7	Butt / Corner
	70 - 90	50 - 70				Lap / Fillet
3.2mm (1/8")	80 - 100	65 - 85	1.6mm (1/16")	2.4mm (3/32")	7	Butt / Corner
	90 - 115	90 - 110				Lap / Fillet
4.8mm (3/16")	115 - 135	100 - 125	2.4mm (3/32")	3.2mm (1/8")	10	Butt / Corner
	140 - 165	125 - 150				Lap / Fillet
6.4mm (1/4")	160 - 175	135 - 160	3.2mm (1/8")	4.0mm (5/32")	10	Butt / Corner
	170 - 200	160 - 180				Lap / Fillet

WT1 80MP Welding Machine

TIG Welding Troubleshooting

Troubleshooting - TIG Weld Quality		
Fault	Cause	Remedy
Excessive beard build up or poor penetration or poor fusion at edges of weld.	Welding current is too low.	Increase weld current and/or faulty joint preparation.
Weld bead too wide and flat or undercut at edges of weld or excessive burn through.	Welding current is too high.	Decrease weld current.
Weld bead too small or insufficient penetration or ripples in bead are widely spaced apart.	Travel speed too fast.	Decrease weld current.
Weld bead too wide or excessive bead build up or excessive penetration in butt joint.	Travel speed too fast.	Increase travel speed.
Uneven leg length in fillet joint.	Wrong placement of filler rod.	Re-position filler rod.
Electrode melts or oxidises when an arc is struck.	Torch lead connected to positive welding terminal.	Connect torch lead to negative welding terminal.
	No gas flowing to welding region.	Check the gas lines for kinks or breaks and gas cylinder contents.
	Torch is clogged with dust or dirt.	Clean torch.
	Gas hose is cut.	Replace gas hose.
	Gas passage contains impurities.	Disconnect gas hose from the rear of Power Source then raise gas pressure and blow out impurities.
	Gas regulator turned off.	Turn on.
	Torch valve is turned off.	Turn on.
Dirty weld pool	The electrode is too small for the welding current.	Increase electrode diameter or reduce the welding current.
	Electrode contaminated by contact with work piece or filler rod material.	Clean the electrode by grinding off any contaminates.
	Work piece surface has foreign material on it.	Clean surface.
Poor weld finish	Gas contaminated with air.	Check gas lines for cuts and loose fitting or change gas cylinder.
	Inadequate shielding gas.	Increase gas flow or check gas line for gas flow problems.
Arc start is not smooth.	Tungsten electrode is too large for the welding current.	Select the right size electrode.
	The wrong electrode is being used for the welding job.	Select the right electrode type.
	Gas flow rate is too high.	Select the right rate for the welding job.
	Incorrect shielding gas is being used.	Select the right shielding gas.
	Poor Work Lead/Clamp connection to work piece.	Improve connection to work piece.
Arc flutters during TIG welding.	Tungsten electrode is too large for the welding current.	Select the right size electrode.

Knowledge & Resources

Please refer to the weldtech website for more information www.weldtech.net.nz

Safety

Store and Retain this Manual

Retain this manual for the safety warnings and precautions, assembly, operating, inspection, maintenance and cleaning procedures. Write the product's serial number into the NOTES section at the rear, and keep this manual and the receipt in a safe and dry place for future reference.

Important Safety Information

Failure to follow the warnings and instructions may result in electric shock, fire, serious injury and/or death. Save all warnings and instructions for future reference.



This is the safety alert symbol to alert you to potential personal injury hazards. Obey all safety messages that follow this symbol to avoid possible injury or death.

 **DANGER!** indicates a hazardous situation which, if not avoided, will result in death or serious injury.

 **WARNING!** indicates a hazardous situation which, if not avoided, could result in death or serious injury.

 **CAUTION,** used with the safety alert symbol, indicates a hazardous situation which, if not avoided, could result in minor or moderate injury.

NOTE, used to address practices not related to personal injury.

CAUTION, without the safety alert symbol, is used to address practices not related to personal injury.

MIG Welding Operation

1. Maintain labels and nameplates on the welder. These carry important information. If unreadable or missing, contact Weldclass for a replacement.

2. Avoid unintentional starting. Make sure the welder is setup correctly and you are prepared to begin work before turning on the welder.

3. Unplug before performing maintenance. Always unplug the welder from its electrical outlet before performing any inspection, maintenance, or cleaning procedures.

4. Never leave the welder unattended while energised. Turn power off before leaving the welder unattended.

5. Do not touch live electrical parts. Wear dry, insulating gloves. Do not touch the electrode or the conductor tong with bare hands. Do not wear wet or damaged gloves.

6. Protect yourself from electric shock. Do not use the welder outdoors. Insulate yourself from the work piece and the ground. Use non-flammable, dry insulating material if possible, or use dry rubber mats, dry wood or plywood, or other dry insulating material large enough to cover the area of contact with the work or the ground.

7. Avoid inhaling dust. Some dust created by power sanding, sawing, grinding, drilling, cutting, welding and other construction activities, contain chemicals known to cause cancer, birth defects or other harm. Your risk from these exposures varies, depending on how often you do this type of work. To reduce your exposure to these chemicals, work in a well-ventilated area, and work with approved safety equipment, such as dust masks that are specially designed to filter out microscopic particles.

8. People with pacemakers should consult their physician(s) before using this machine.

 **WARNING!**
Electromagnetic fields in close proximity to a heart pacemaker could cause interference, or failure of the pacemaker. The use of a Welder is **NOT RECOMMENDED** for pacemaker wearers. Consult your doctor.

9. Ensure that the unit is placed on a stable location before use.

 **WARNING!**
If this unit falls while plugged in, severe injury, electric shock, or fire may result.

WT1 80MP Welding Machine

10. Transportation Methods. Lift unit with the handles provided, or use a handcart or similar device of adequate capacity. If using a fork lift vehicle, secure the unit to a skid before transporting.

 **CAUTION!**
Disconnect input power conductors from de-energized supply line before moving the welding power source.

11. Exercise good work practices. The warnings, precautions, and instructions discussed in this instruction manual cannot cover all possible conditions and situations that may occur. It must be understood by the operator that common sense and caution are factors which cannot be built into this product, but must be considered by the operator.

Welding Safety Instructions & Warnings

 **WARNING!**
Protect yourself and others from possible serious injury or death. Keep children away. Read the operating/Instruction manual before installing, operating or servicing this equipment. Have all installation, operation, maintenance, and repair work performed by qualified people.

If an operator does not strictly observe all safety rules and take precautionary actions, welding products and welding processes can cause serious injury or death, or damage to other equipment or property.

Safe practices have developed from past experience in the use of welding and cutting. These practices must be learned through study and training before using this equipment. Some of these practices apply to equipment connected to power lines; other practices apply to engine driven equipment. Anyone not having extensive training in welding and cutting practices should not attempt to weld.

Safe practices are outlined in the European Standard EN60974-1 entitled: Safety in welding and allied processes.

 **WARNING!**
Only use safety equipment that has been approved by an appropriate standards agency. Unapproved safety equipment may not provide adequate protection. Eye and breathing protection must be AS/NZS compliant for the specific hazards in the work area.

 **DANGER!**
Always wear AS/NZS compliant safety glasses and full face shield fitted with appropriate filter shade number. (Refer Filter Table on page 17.)

 **CAUTION!**
Heavy-duty work gloves, non-skid safety shoes and hearing protection used for appropriate conditions will reduce personal injuries.

 **CAUTION!**
Have the equipment serviced by a qualified repair person using identical replacement parts. This will ensure that the safety of the power tool is maintained.

Personal Safety

 **CAUTION!**
Keep the work area well lit. Make sure there is adequate space surrounding the work area. Always keep the work area free of obstructions, grease, oil, trash, and other debris. Do not use equipment in areas near flammable chemicals, dust, and vapours. Do not use this product in a damp or wet location.

1. Stay alert, watch what you are doing and use common sense when operating equipment. Do not use a tool while you are tired or under the influence of drugs, alcohol or medication. A moment of distraction when operating equipment may result in serious personal injury.
2. Do not overreach. Keep proper footing and balance at all times. This enables better control of the power tool in unexpected situations.

Arc Rays can Burn Eyes and Skin

 **CAUTION!**
Arc rays from the welding process produce intense heat and strong ultraviolet rays that can burn eyes and skin.

1. Use a Welding Helmet or Welding Face Shield fitted with a proper shade filter (refer AS 60974-1, AS/NZS 1337.1 and AS/NZS 1338.1 Safety Standards) to protect your face and eyes when welding or watching. (See Filter Table on Page 17).
2. Wear approved safety glasses. Side shields are recommended.

3. Use protective screens or barriers to protect others from flash and glare; warn others not to watch the arc.
4. Wear protective clothing made from durable, flame-resistant material (wool and leather) and foot safety protection.
5. Never wear contact lenses while welding.

Noise Can Damage Hearing



CAUTION!

Noise from some processes can damage hearing. Use AS/NZS compliant ear plugs or ear muffs if the noise level is high.

Work Environment Safety



DANGER!

Remove any combustible material from the work area.

1. When possible, move the work to a location well away from combustible materials. If relocation is not possible, protect the combustibles with a cover made of fire resistant material.
2. Remove or make safe all combustible materials for a radius of 10 metres around the work area. Use a fire resistant material to cover or block all doorways, windows, cracks, and other openings.
3. Enclose the work area with portable fire resistant screens. Protect combustible walls, ceilings, floors, etc., from sparks and heat with fire resistant covers.
4. If working on a metal wall, ceiling, etc., prevent ignition of combustibles on the other side by moving the combustibles to a safe location. If relocation of combustibles is not possible, designate someone to serve as a fire watch, equipped with a fire extinguisher, during the welding process and well after the welding is completed.
5. Do not weld or cut on materials having a combustible coating or combustible internal structure, as in walls or ceilings, without an approved method for eliminating the hazard.
6. After welding, make a thorough examination for evidence of fire. Be aware that visible smoke or flame may not be present for some time after the fire has started. Do not weld or cut in atmospheres containing dangerously reactive or flammable gases, vapours, liquids, and dust. Provide adequate ventilation in work areas to prevent accumulation of flammable gases, vapours, and dust.

7. Do not apply heat to a container that has held an unknown substance or a combustible material whose contents, when heated, can produce flammable or explosive vapours. Clean and purge containers before applying heat. Vent closed containers, including castings, before preheating, welding, or cutting.

Electricity Can Kill



DANGER!

Touching live electrical parts can cause fatal shocks or severe burns. The electrode and work circuit is electrically live whenever the output is on.

The input power circuit and machine internal circuits are also live when power is on. In semi-automatic or automatic wire welding, the wire, wire reel, drive roll housing, and all metal parts touching the welding wire are electrically live. Incorrectly installed or improperly grounded equipment is a hazard.

1. Do not touch live electrical parts.
2. Wear dry, hole-free insulating gloves and body protection.
3. Insulate yourself from the work and the ground using dry insulating mats or covers.
4. Disconnect input power before installing or servicing this equipment. Lock input power, disconnect switch open, or remove line fuses so power cannot be turned on accidentally.
5. Properly install and ground this equipment according to national, state, and local codes.
6. Turn off all equipment when not in use. Disconnect power to equipment if it will be left unattended or out of service.
7. Use fully insulated electrode holders. Never dip the holder in water to cool it or lay it down on the ground or the work surface. Do not touch holders connected to two welding machines at the same time or touch other people with the holder or electrode.
8. Do not use worn, damaged, undersized, or poorly spliced cables.
9. Do not wrap cables around your body.
10. Connect work piece to a good electrical ground.

WT1 80MP Welding Machine

11. Do not touch the electrode while in contact with the work (ground) circuit.
12. Use only well-maintained equipment. Repair or replace damaged parts as soon as practical.
13. In confined spaces or damp locations, do not use a welder with AC output unless equipped with a voltage reducer.

Arc rays from the welding process produce intense heat and strong ultraviolet rays that can burn eyes and skin. Use the following table to select the appropriate shade number for a Welding Helmet or Welding Face Shield.

1. Use a Welding Helmet or Welding Face Shield fitted with a proper shade of filter (see AS 60974-1, AS/NZS 1337.1 and AS/NZS 1338.1 Safety Standards) to protect your face and eyes when welding or watching.
2. Wear approved safety glasses. Side shields are recommended.
3. Use protective screens or barriers to protect others from flash and glare; warn others not to watch the arc.
4. Wear protective clothing made from durable, flame-resistant material (wool and leather) and foot protection.
5. Never wear contact lenses while welding.

Recommended Protective Filters for Electric Welding		
Description of Process	Approximate Range of Welding Current in Amps	Minimum Shade Number of Filter(s)
Manual Metal Arc Welding - Covered Electrodes (MMA)	Less than or equal to 100	8
	100 to 200	10
	200 to 300	11
	300 to 400	12
	Greater than 400	13
Gas Metal Arc Welding (GMAW) (MIG) other than Aluminium And Stainless Steel	Less than or equal to 150	10
	150 to 250	11
	250 to 300	12
	300 to 400	13
	Greater than 400	14
Gas Metal Arc Welding (GMAW) (MIG) Aluminium and Stainless Steel	Less than or equal to 250	12
	250 to 350	13
Gas Tungsten Arc Welding (GTAW) (TIG)	Less than or equal to 100	10
	100 to 200	11
	200 to 250	12
	250 to 350	13
	Greater than 350	14
Flux-Cored Arc Welding (FCAW) - with or without Shielding Gas	Less than or equal to 300	11
	300 to 400	12
	400 to 500	13
	Greater than 500	14
Air - Arc Gouging	Less than or equal to 400	12
Plasma - Arc Cutting	50 to 100	10
	100 to 400	12
	400 to 800	14
Plasma - Arc Spraying	—	15
Plasma - Arc Welding	Less than or equal to 20	8
	20 to 100	10
	100 to 400	12
	400 to 800	14
Submerged - Arc Welding	—	2 (5)
Resistance Welding	—	Safety Spectacles or Eye Shield

Refer to standard AS/NZS 1338.1 for comprehensive information regarding the above table.

Fumes And Gases



WARNING!

Welding produces fumes and gases. Breathing these fumes and gases can be hazardous to your health.

1. Keep your head out of the fumes. Do not breathe the fumes.
2. If inside, ventilate the area and/or use an exhaust at the arc to remove welding fumes and gases.

3. If ventilation is poor, use an approved air-supplied respirator.
4. Read the Safety Data Sheets (SDS) and the manufacturer's instruction for the metals, consumables, coatings, and cleaners.
5. Work in a confined space only if it is well ventilated, or while wearing an air-supplied respirator. Shielding gases used for welding can displace air causing injury or death. Be sure the breathing air is safe.
6. Do not weld in locations near degreasing, cleaning, or spraying operations. The heat and rays of the arc can react with vapours to form highly toxic and irritating gases.
7. Do not weld on coated metals, such as galvanized, lead, or cadmium plated steel, unless the coating is removed from the weld area, the area is well ventilated, and if necessary, while wearing an air-supplied respirator. The coatings and any metals containing these elements can give off toxic fumes if welded.
8. Connect the work lead/clamp to the job as close to the welding area as practical to prevent welding current from traveling long, possibly unknown paths and causing electric shock and fire hazards.
9. Do not use a welder to thaw frozen pipes.
10. Remove the stick electrode from the holder or cut off the welding wire at the contact tip when not in use.

Fire & Explosive Risks



WARNING!

Sparks and spatter fly off from the welding arc. The flying sparks and hot metal, weld spatter, work piece, and hot equipment can cause fires and burns.

Accidental contact of electrode or welding wire to metal objects can cause sparks, overheating, or fire.

1. Protect yourself and others from flying sparks and hot metal.
2. Do not weld where flying sparks can strike flammable material.
3. Remove all flammables within 10m of the welding site.
4. Be alert that welding sparks and hot materials from welding can easily go through small cracks and openings to adjacent areas.
5. Watch for fire, and keep a fire extinguisher nearby.
6. Be aware that welding on a ceiling, floor, bulkhead, or partition can cause fire on the hidden side.
7. Do not weld on closed containers such as tanks or drums.

Sparks & Hot Metal



WARNING!

Chipping and grinding causes flying metal, and as welds cool they can throw off slag.

1. Wear an AS/NZS approved face shield or safety goggles. Side shields are recommended.
2. Wear appropriate safety equipment to protect the skin and body.

Cylinders



WARNING!

Gas cylinders contain gas under high pressure. If damaged, a cylinder can explode. Since gas cylinders are normally part of the welding process, be sure to treat them carefully.

1. Protect compressed gas cylinders from excessive heat, mechanical shocks, and arcs.
2. Install and secure cylinders in an upright position by chaining them to a stationary support or equipment cylinder rack to prevent falling or tipping.
3. Keep cylinders away from any welding or other electrical circuits.
4. Never allow a welding electrode to touch any cylinder.
5. Use appropriate shielding gas, regulators, hoses, and fittings designed for the specific application; maintain them and their associated parts in good condition.
6. Turn your face away from the valve outlet when opening the cylinder valve.

WT1 80MP Welding Machine

Warranty

As part of an on-going commitment to excellence in product support, Euroquip offers a comprehensive product warranty program.

In order to qualify for full warranty support, your product must be registered.

Product not registered with Euroquip is supported by a base 12 month warranty only. Spare parts and technical support will not be available for an unregistered product outside of this base warranty period. If a Euroquip dealer has not already registered your product, please register it online at www.euroquip.co.nz. To request a physical registration form, please contact Euroquip customer service on 0800 387 678.

Registered warranty period for the WT180MP:

Commercial Use: 18 Months

Domestic Use: 18 Months

Warranty covers failure caused by manufacturing and material defects in the product, during the warranty period specified. The warranty period begins when the product is purchased by the end user. Warranty is not transferrable and is only claimable by the original purchaser.

Warranty does not cover parts that are subject to wear and tear from usage.

Warranty covers failure of a product caused by defective materials and/or manufacturing for the period given and the usage specified by Euroquip. The warranty period begins when the product is purchased by the end user. Warranty is not transferrable and is only claimable by the original purchaser.

Warranty also does not cover failure caused by the untimely replacement or service of the above wearing parts. Evidence must be provided that the product has been maintained and serviced suitably for a claim to be considered under warranty.

Failure caused by incorrect operation of the product, lack of proper care and maintenance of the product, external damage, external circumstances such as contaminated fuel or poor water supply, modifications to the product, attempted repair/ service by a party other than an Approved Service Agent, is not covered under warranty.

Warranty does not cover pre delivery service and ad-

justment, or failure that may occur as a result of lack of/ incorrect pre delivery service and adjustment.

Warranty does not cover any incidental, indirect or consequential loss, damage or expense that may result from any defect, failure or malfunction of a product.

Should any issue be found to be a combination of a warranty failure and a non-warranty issue, the repair cost component to rectify and repair the non-warranty failure is the customers' full responsibility.

The decision that an issue with a product qualifies as a warranty claim is made at the sole jurisdiction of Euroquip.

No costs incurred will be considered under warranty if repairs are carried out by a party other than a Euroquip Approved Service Agent, unless with prior consent in writing from Euroquip.

It is the responsibility of the purchaser to deliver a product under warranty to the nearest relevant service agent or product reseller. Warranty does not cover call outs, mileage and freight costs.

If a product is repaired under warranty, parts and labour required for the repair will be supplied at no charge. Warranty assessment and repair will be scheduled and executed according to the normal work flow at the service location and depending on the availability of suitable replacement parts.

This warranty policy is an additional benefit and does not affect the legal rights of any end user, reseller or service agent.



Scan here to register your product

WT1 80MP Welding Machine



Congratulations on your new WELDTECH product. We are proud to have you as our customer and will strive to provide you with the best service and reliability in the industry. This product is backed by our extensive warranty and service network. To locate your nearest distributor or service agency visit www.weldtech.net.nz, or email us at customerservice@euroquip.co.nz

www.weldtech.net.nz